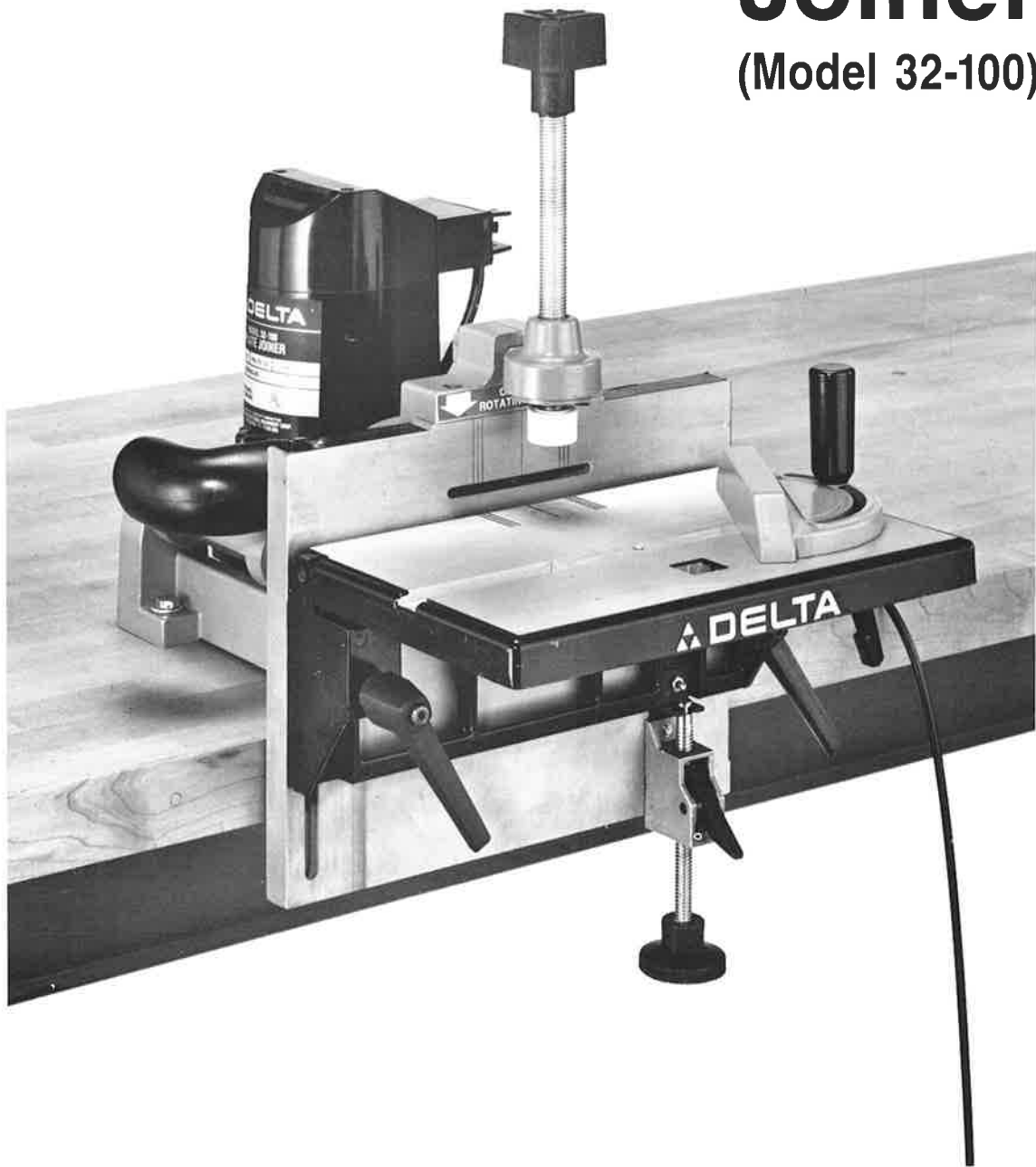

Plate Joiner

(Model 32-100)

INSTRUCTION MANUAL



DATED 7-1-92

PART NO. 1345323
©Delta International Machinery Corp. 1992



TABLE OF CONTENTS

SAFETY RULES	3
ADDITIONAL SAFETY RULES FOR PLATE JOINER	4
ASSEMBLY INSTRUCTIONS	
Assembling Table	4
Assembling Micro-Set Table Adjuster	6
Positioning Safety Guard On Foot Pedal	6
Assembling Cable Assembly	7
Assembling Adjustable Stock Stop To Table	7
Dual Position Work Clamp	8
Dust Chute	8
FASTENING MACHINE TO SUPPORTING SURFACE	8
CONNECTING PLATE JOINER TO POWER SOURCE	
Power Connections	9
Grounding Instructions	9
OPERATING CONTROLS AND ADJUSTMENTS	
Raising And Lowering Table	10
Tilting The Table	10
Adjusting Table 90 Degrees To Fence	11
Starting And Stopping Machine	11
Locking Switch In The "OFF" Position	11
Depth of Cut Control	12
Checking And Adjusting Depth Of Cut	12
Foot Pedal	12
Adjusting Foot Pedal Cable	12
Replacing Cutter	13
SOME TYPICAL OPERATIONS	13
Edge Joining	13
Bevel Edge Joining	14
Bevel End Joining	15
Butt Joining	16
Miter Joining	17
AUTHORIZED SERVICE STATIONS	18-19
PARTS, SERVICE OR WARRANTY ASSISTANCE	20
WARRANTY	20

SAFETY RULES

As with all machinery there are certain hazards involved with operation and use of the machine. Using the machine with respect and caution will considerably lessen the possibility of personal injury. However, if normal safety precautions are overlooked or ignored, personal injury to the operator may result.

This machine was designed for certain applications only. Delta Machinery strongly recommends that this machine NOT be modified and/or used for any application other than for which it was designed. If you have any questions relative to its application DO NOT use the machine until you have written Delta Machinery and we have advised you.

DELTA INTERNATIONAL MACHINERY CORP.
MANAGER OF TECHNICAL SERVICES
246 ALPHA DRIVE
PITTSBURGH, PENNSYLVANIA 15238
(IN CANADA: 644 IMPERIAL ROAD, GUELPH, ONTARIO N1H 6M7)

WARNING: FAILURE TO FOLLOW THESE RULES MAY RESULT IN SERIOUS PERSONAL INJURY

- 1. FOR YOUR OWN SAFETY, READ INSTRUCTION MANUAL BEFORE OPERATING THE TOOL.** Learn the tool's application and limitations as well as the specific hazards peculiar to it.
- 2. KEEP GUARDS IN PLACE** and in working order.
- 3. ALWAYS WEAR EYE PROTECTION.**
- 4. GROUND ALL TOOLS.** If tool is equipped with three-prong plug, it should be plugged into a three-hole electrical receptacle. If an adapter is used to accommodate a two-prong receptacle, the adapter lug must be attached to a known ground. Never remove the third prong.
- 5. REMOVE ADJUSTING KEYS AND WRENCHES.** Form habit of checking to see that keys and adjusting wrenches are removed from tool before turning it "on."
- 6. KEEP WORK AREA CLEAN.** Cluttered areas and benches invite accidents.
- 7. DON'T USE IN DANGEROUS ENVIRONMENT.** Don't use power tools in damp or wet locations, or expose them to rain. Keep work area well-lighted.
- 8. KEEP CHILDREN AND VISITORS AWAY.** All children and visitors should be kept a safe distance from work area.
- 9. MAKE WORKSHOP CHILDPROOF** - with padlocks, master switches, or by removing starter keys.
- 10. DON'T FORCE TOOL.** It will do the job better and be safer at the rate for which it was designed.
- 11. USE RIGHT TOOL.** Don't force tool or attachment to do a job for which it was not designed.
- 12. WEAR PROPER APPAREL.** No loose clothing, gloves, neckties, rings, bracelets, or other jewelry to get caught in moving parts. Non-slip foot wear is recommended. Wear protective hair covering to contain long hair.
- 13. ALWAYS USE SAFETY GLASSES.** Wear safety glasses (must comply with ANSI Z87.1). Everyday eyeglasses only have impact resistant lenses; they are not safety glasses. Also use face or dust mask if cutting operation is dusty.
- 14. SECURE WORK.** Use clamps or a vise to hold work when practical. It's safer than using your hand and frees both hands to operate tool.
- 15. DON'T OVERREACH.** Keep proper footing and balance at all times.
- 16. MAINTAIN TOOLS IN TOP CONDITION.** Keep tools sharp and clean for best and safest performance. Follow instructions for lubricating and changing accessories.
- 17. DISCONNECT TOOLS** before servicing and when changing accessories such as blades, bits, cutters, etc.
- 18. USE RECOMMENDED ACCESSORIES.** The use of improper accessories may cause hazards.
- 19. AVOID ACCIDENTAL STARTING.** Make sure switch is in "OFF" position before plugging in power cord.
- 20. NEVER STAND ON TOOL.** Serious injury could occur if the tool is tipped or if the cutting tool is accidentally contacted.
- 21. CHECK DAMAGED PARTS.** Before further use of the tool, a guard or other part that is damaged should be carefully checked to ensure that it will operate properly and perform its intended function - check for alignment of moving parts, binding of moving parts, breakage of parts, mounting, and any other conditions that may affect its operation. A guard or other part that is damaged should be properly repaired or replaced.
- 22. DIRECTION OF FEED.** Feed work into a blade or cutter against the direction of rotation of the blade or cutter only.
- 23. NEVER LEAVE TOOL RUNNING UNATTENDED. TURN POWER OFF.** Don't leave tool until it comes to a complete stop.
- 24. DRUGS, ALCOHOL, MEDICATION.** Do not operate tool while under the influence of drug, alcohol or any medication.
- 25. MAKE SURE TOOL IS DISCONNECTED FROM POWER SUPPLY** while motor is being mounted, connected or reconnected.
- 26. WARNING:** The dust generated by certain woods and wood products can be injurious to your health. Always operate machinery in well ventilated areas and provide for proper dust removal. Use wood dust collection systems whenever possible.

ADDITIONAL SAFETY RULES FOR PLATE JOINER

1. **WARNING:** Do not operate your machine until it is completely assembled and installed according to the instructions.
2. **IF YOU ARE NOT** thoroughly familiar with the operation of Plate Joiners, obtain advice from your supervisor, instructor or other qualified person.
3. **MAKE CERTAIN** that machine is securely attached to support table before operating.
4. **CHECK** to make sure that cutter blade is securely fastened.
5. **KEEP** fingers out of path of cutting blade.
6. **USE** the adjustable stock stop and dual position work clamp provided to properly secure and control workpiece whenever possible.
7. **ALWAYS** wear eye protection
8. **NEVER** reach behind or over cutting tool with either hand for any reason.
9. **PROVIDE** adequate support to the rear and sides of the work support table for wide or long workpieces.
10. **AVOID** operations and hand positions where a sudden slip could cause your hand to move into the cutting tool.
11. **NEVER** perform layout, assembly or set-up work on the table while the machine is operating.
12. **ALWAYS** turn the machine "OFF" and disconnect the cord from the power source before installing or removing the blade.
13. **NEVER** leave the machine work area when the power is "ON" or before the machine has come to a complete stop.

ASSEMBLY INSTRUCTIONS

ASSEMBLING TABLE

1. Place the motor and fence assembly (A) Fig. 2, on a flat supporting surface or workbench, as shown.
2. Position table (B) Fig. 2, so guide (C) will rest inside channel (D) of fence.

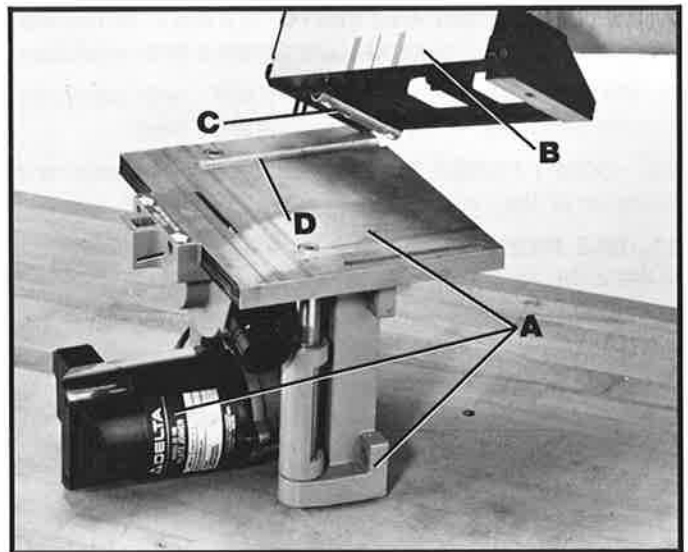

Fig. 2

3. Locate the two table locking handle assemblies, shown in Fig. 3.

4. Remove screw (A) Fig. 3, spring (B) and handle (C) from shaft assembly (D).

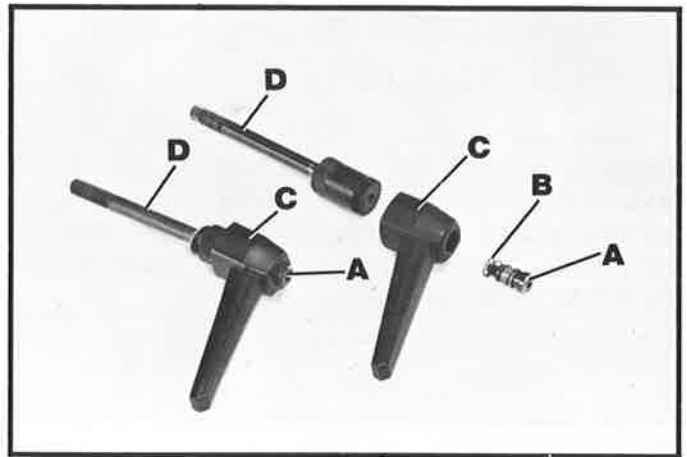

Fig. 3

5. Place flat washer (E) Fig. 4, on shaft assembly (D) and insert threaded portion of shaft assembly (D) through holes in table and fence, as shown.

6. Place square nut (F) Fig. 4, in position in channel in back of fence (G) and thread shaft assembly (D) into nut (F). **NOTE: ROUNDED SIDE OF NUT (F) SHOULD BE AGAINST FENCE AND FLAT SIDE OF NUT (F) SHOULD BE TOWARD THE OUTSIDE.**

7. Assemble the remaining shaft assembly in the same manner.

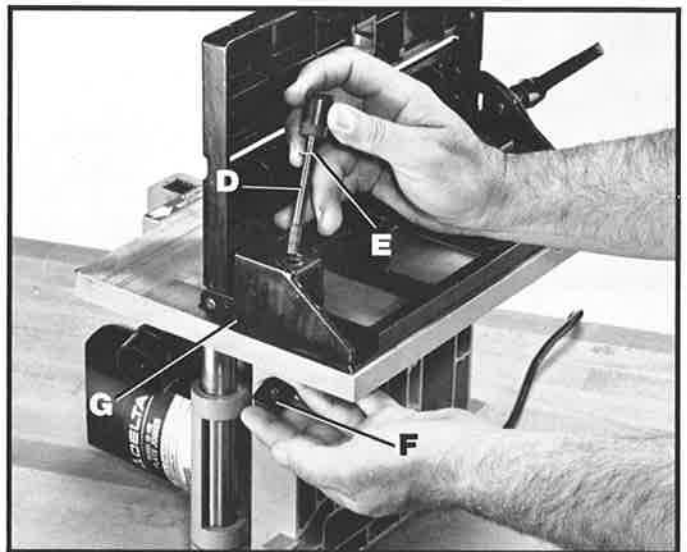

Fig. 4

8. Replace the locking handles (C) Fig. 5, spring and screw (A) to shaft assemblies. These items were removed in **STEP 4**. Tighten handles (C) to lock the table in position. **IMPORTANT: WHEN TIGHTENING TABLE LOCK HANDLES (C) ALWAYS TIGHTEN THE RIGHT HAND HANDLE FIRST TO INSURE TABLE IS LEVEL ON BOTH SIDES.** **NOTE:** Lock handles (C) are spring loaded and can be repositioned by pulling out on the handle and repositioning it on the serrated nut located underneath the hub of the handle.

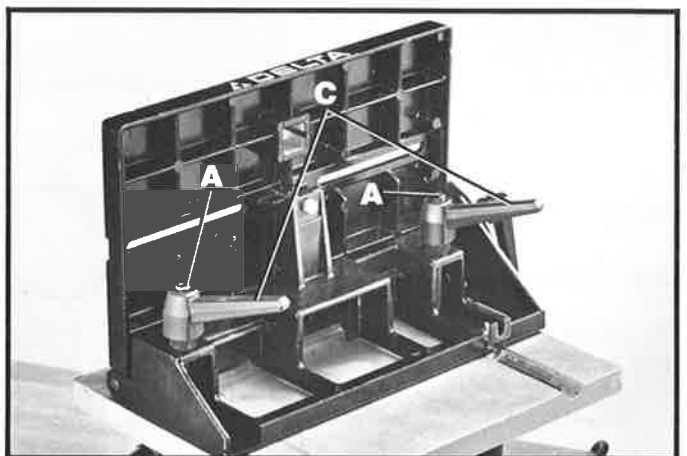

Fig. 5

ASSEMBLING MICRO-SET TABLE ADJUSTER

1. Make sure top of screw (A) Fig. 6, is engaged with bracket (B) and insert bracket assembly (C) in channel (D). Fasten bracket assembly (C) to fence (E) using screw (F) and washer (G). Do not tighten screw (F). Turn knob (H) until bracket (C) is down as far as possible in channel (D) and tighten screw (F).

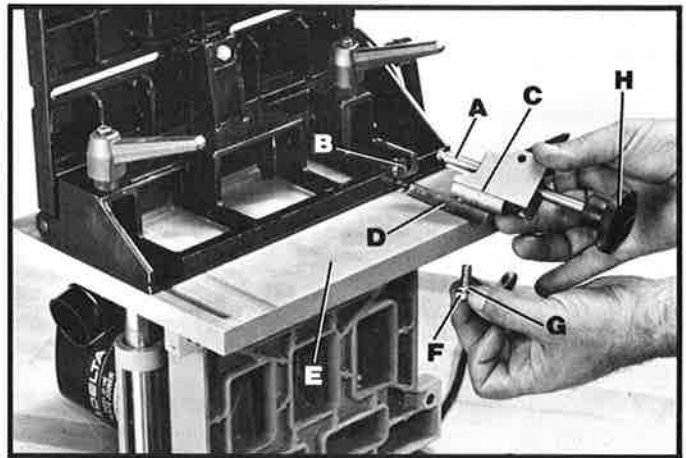

Fig. 6

2. Fig. 7, illustrates the micro-set table adjuster correctly assembled to the table and fence.

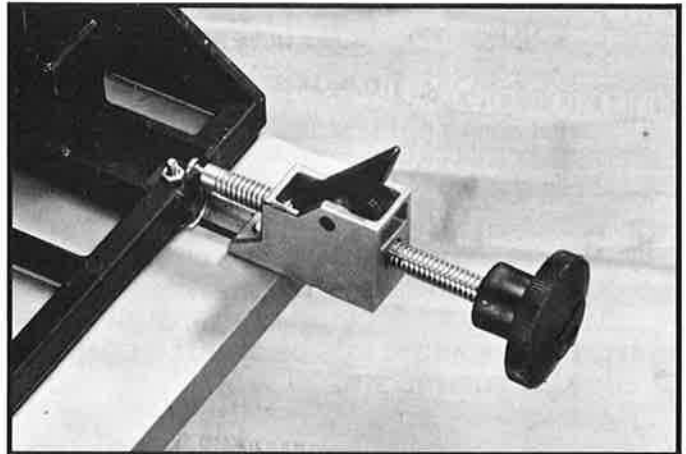

Fig. 7

3. Position machine so it rests over edge of the supporting surface, as shown in Fig. 8.

4. **IMPORTANT: TO AVOID PERSONAL INJURY OR DAMAGE TO THE MACHINE, WE STRONGLY SUGGEST THAT THE MACHINE BE FASTENED TO THE SUPPORTING SURFACE DURING THE REST OF THE ASSEMBLY PROCEDURE USING CLAMPS OR FASTENERS.**

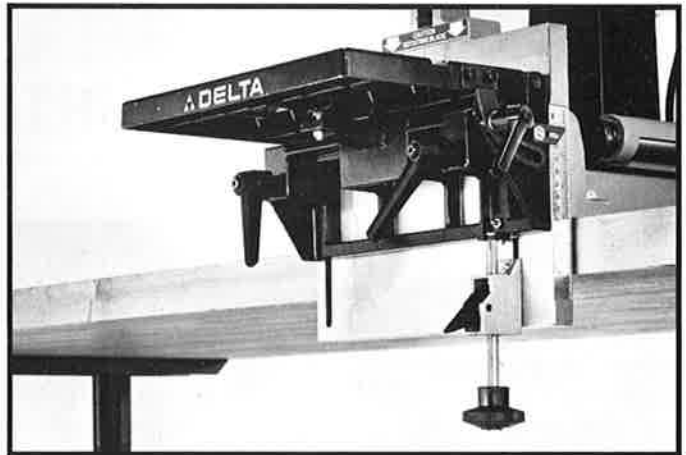

Fig. 8

POSITIONING SAFETY GUARD ON FOOT PEDAL

1. Lift up and rotate guard (A) Fig. 9, until hole in guard lines up with hole (B) in foot pedal assembly. Fasten guard (A) in place with lockwasher (C) and threaded lock knob (D).

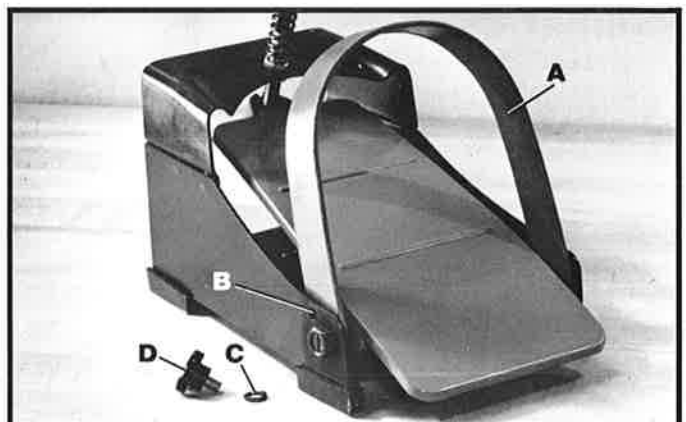

Fig. 9

ASSEMBLING CABLE ASSEMBLY

The cable assembly (A) Fig. 10, is shipped from the factory with one end of the cable assembled to the foot pedal. The free end, however, must be mounted to the rear of the machine, as follows:

1. Insert the cable assembly (A) Fig. 10, thru hole in casting and fasten using hex nut (B) supplied. **NOTE:** Hex nut (C) was threaded onto cable assemble at the factory.

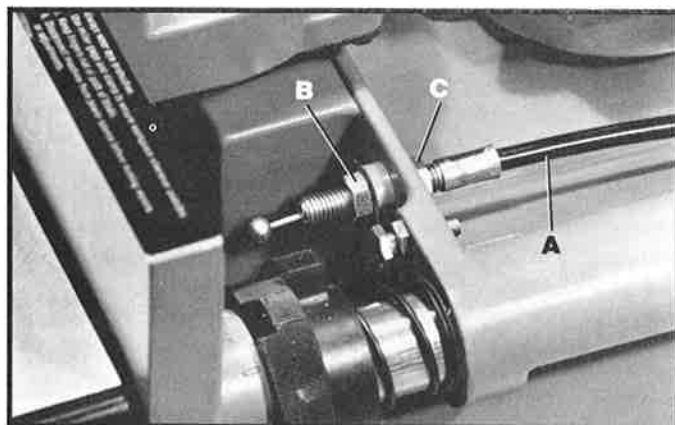

Fig. 10

2. Position cable shield (D) Fig. 11, over cable and insert end of cable (E) into slotted bracket (F). **NOTE:** If end of cable (E) does not reach slotted bracket (F) it will be necessary to tighten and/or loosen the two nuts (B) and (C).

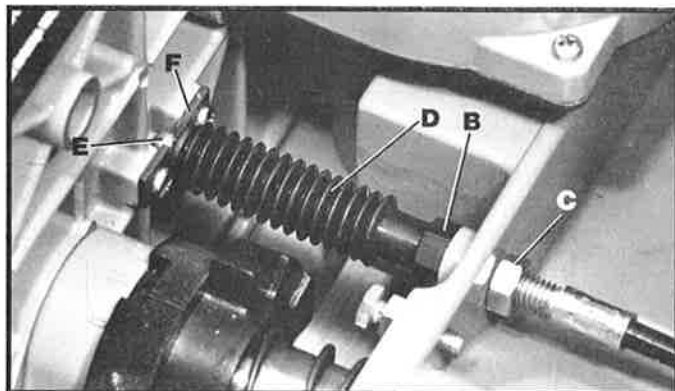

Fig. 11

ASSEMBLING ADJUSTABLE STOCK STOP TO TABLE

1. When using the adjustable stock stop, place bar (A) Fig. 12, in groove (B) of table. Fasten the bar to the table using lock knob (C) and washer (D). Thread lock knob (C) up through one of the slots in the table groove and into one of the two threaded holes (E) in bar.

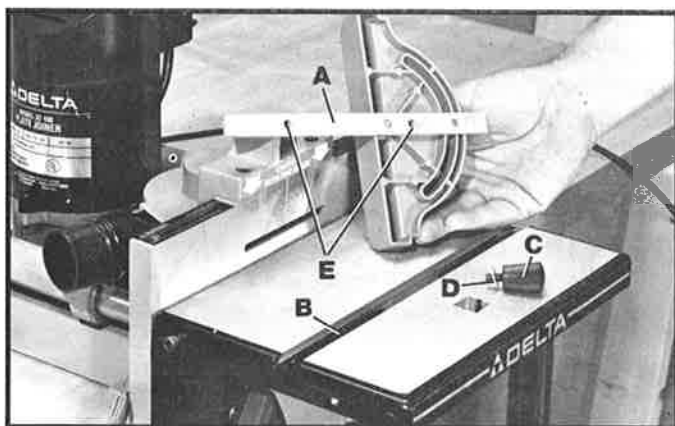

Fig. 12

2. The adjustable stock stop can be used in the right hand position, as shown in Fig. 13, or in the left hand position, as shown in Fig. 14.

3. To rotate the stock stop body (E) Fig. 13 and 14, for angles, simply loosen lock handle (F), rotate body (E) to the angle of the workpiece. Then tighten handle (F).

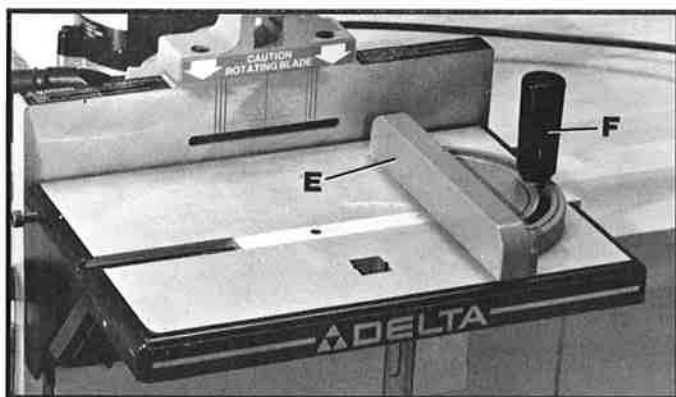

Fig. 13

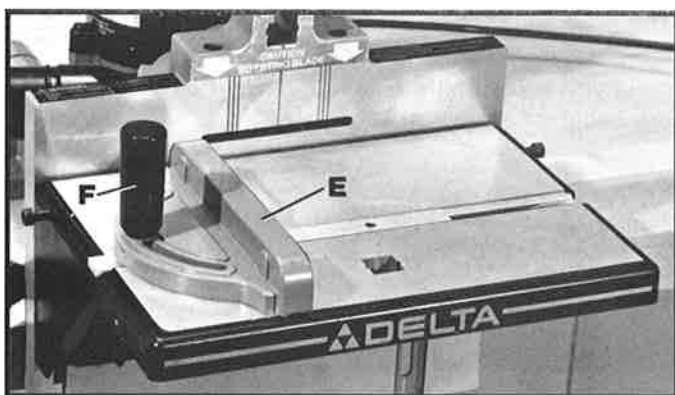

Fig. 14

DUAL POSITION WORK CLAMP

The dual position work clamp can be used in the vertical position, as shown in Fig. 15, or in the horizontal position, as shown in Fig. 16.

To instantly position the clamp (A) Fig. 15 and Fig. 16, against the workpiece, simply turn the handle (B) counter-clockwise one-half turn and rapidly slide the threaded shaft (C) until the clamp (A) is against the work. Then tighten the clamp (A) by turning the handle (B) clockwise.

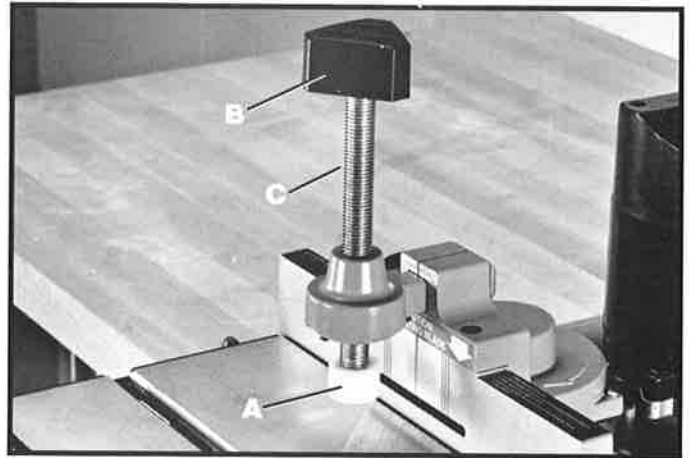

Fig. 15

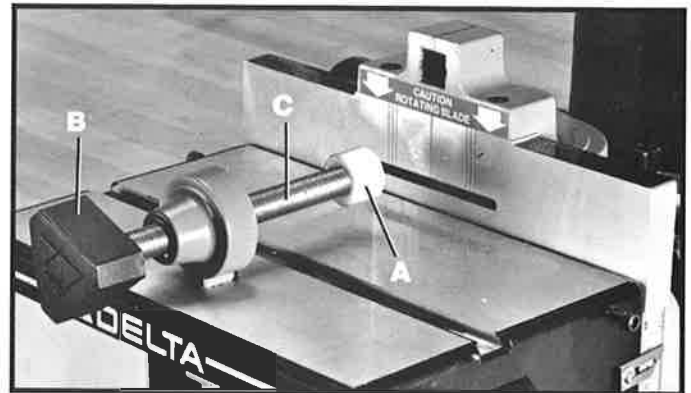

Fig. 16

DUST CHUTE

A dust chute (A) is supplied for use with your plate joiner and is to be assembled to the chip exhaust (B) on the left rear side of the machine, as shown in Fig. 17. The plate joiner can be connected directly to the Delta accessory 49-255 28-gallon, all purpose vacuum cleaner by removing the dust chute (A) Fig. 17, and using the accessory 49-220 (2½" x 1½") adapter and the accessory 49-228 (2½" x 2½") coupling. The hose from the 49-255 vacuum cleaner can then be connected to the coupling.

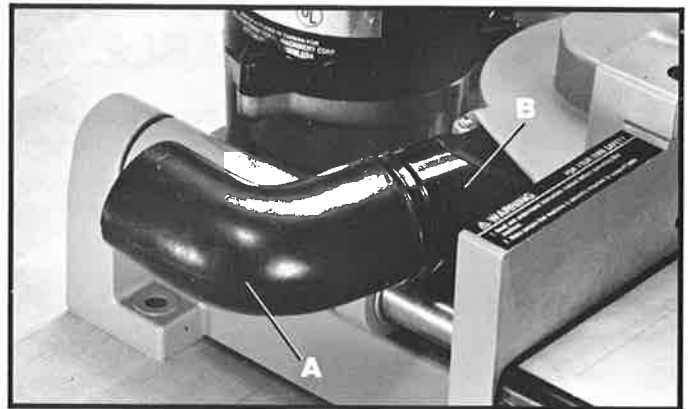

Fig. 17

FASTENING MACHINE TO SUPPORTING SURFACE

The plate joiner must always be fastened to a supporting surface using clamps or by using bolts through the four mounting holes in the machine base. Two of the mounting bolts are shown at (A) Fig. 18.

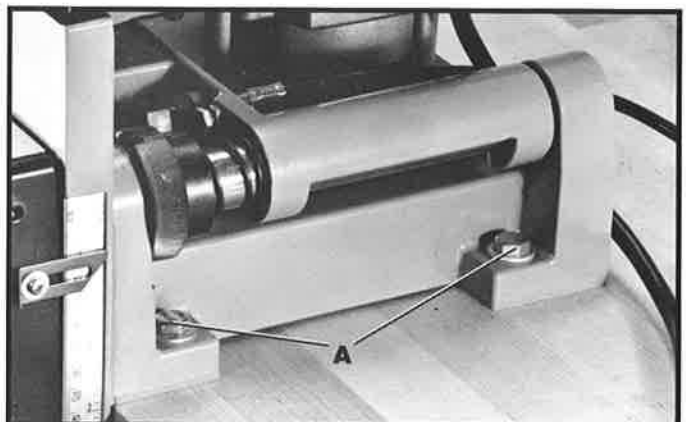

Fig. 18

CONNECTING PLATE JOINER TO POWER SOURCE

POWER CONNECTIONS

A separate electrical circuit should be used for your tools. This circuit should not be less than #12 wire and should be protected with a 20 Amp time lag fuse. If an extension cord is used, use only 3-wire extension cords which have 3-prong grounding type plugs and 3-pole receptacles which accept the tools plug. For distances up to 100 feet use #12 wire. For distances up to 150 feet use #10 wire. Have a certified electrician replace or repair damaged or worn cord immediately. Before connecting the motor to the power line, make sure the switch is in the "OFF" position and be sure that the electric current is of the same characteristics as stamped on motor nameplate. All line connections should make good contact. Running on low voltage will damage the motor.

GROUNDING INSTRUCTIONS

CAUTION: THIS TOOL MUST BE GROUNDED WHILE IN USE TO PROTECT THE OPERATOR FROM ELECTRIC SHOCK.

In the event of a malfunction or breakdown, grounding provides a path of least resistance for electric current to reduce the risk of electric shock. This tool is equipped with an electric cord having an equipment-grounding conductor and a grounding plug. The plug must be plugged into a matching outlet that is properly installed and grounded in accordance with all local codes and ordinances.

Do not modify the plug provided - if it will not fit the outlet, have the proper outlet installed by a qualified electrician.

Improper connection of the equipment-grounding conductor can result in risk of electric shock. The conductor with insulation having an outer surface that is green with or without yellow stripes is the equipment-grounding conductor. If repair or replacement of the electric cord or plug is necessary, do not connect the equipment-grounding conductor to a live terminal.

Check with a qualified electrician or service personnel if the grounding instructions are not completely understood, or if in doubt as to whether the tool is properly grounded.

Use only 3-wire extension cords that have 3-prong grounding type plugs and 3-hole receptacles that accept the tool's plug, as shown in Fig. 19.

Repair or replace damaged or worn cord immediately.

This tool is intended for use on a circuit that has an outlet and a plug that looks like the one shown in Fig. 19. A temporary adapter, which looks like the adapter illustrated in Fig. 20, may be used to connect this plug to a 2-pole receptacle, as shown in Fig. 20, if a properly grounded outlet is not available. The temporary adapter should be used only until a properly grounded outlet can be installed by a qualified electrician. **THIS ADAPTER IS NOT APPLICABLE IN CANADA.** The green-colored rigid ear, lug, and the like, extending from the adapter must be connected to a permanent ground, such as properly grounded outlet box, as shown in Fig. 20.

CAUTION: IN ALL CASES, MAKE CERTAIN THE RECEPTACLE IN QUESTION IS PROPERLY GROUNDED. IF YOU ARE NOT SURE HAVE A CERTIFIED ELECTRICIAN CHECK THE RECEPTACLE.

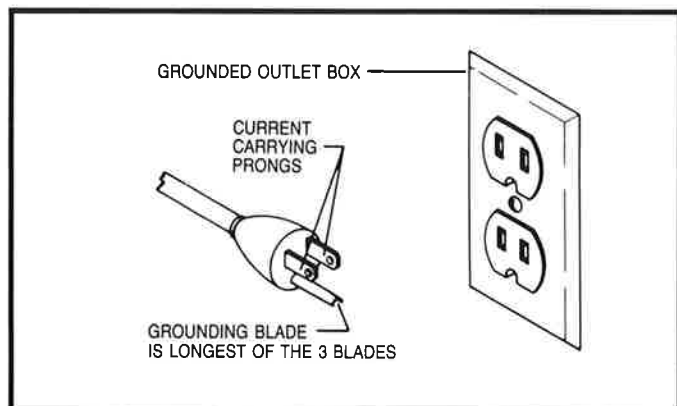

Fig. 19

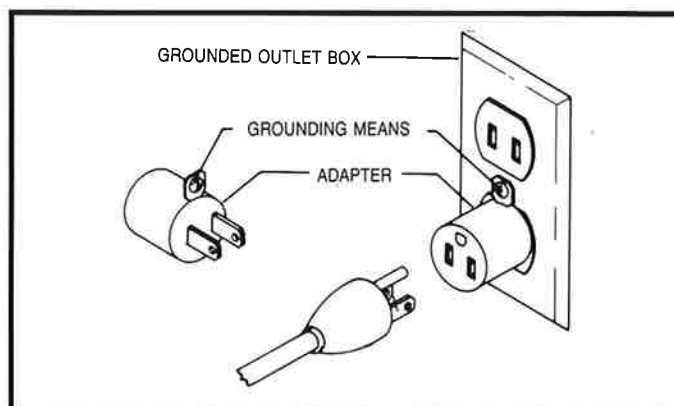

Fig. 20

OPERATING CONTROLS AND ADJUSTMENTS

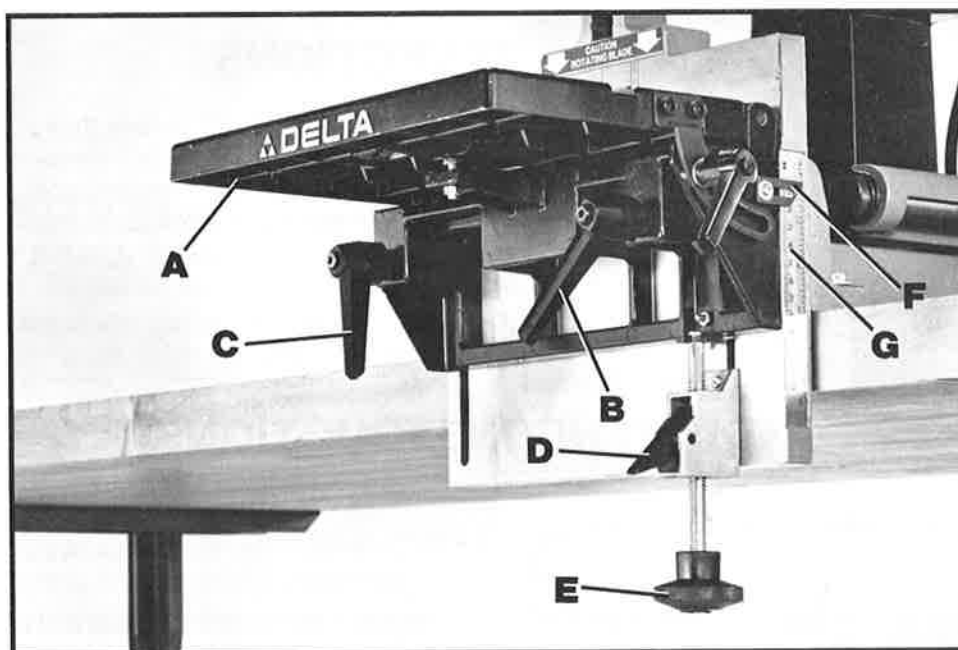

Fig. 21

RAISING AND LOWERING TABLE

1. To raise the table (A) Fig. 21, loosen the two table lock levers (B) and (C), manually raise table (A) to the desired height and tighten lock levers (B) and (C). **IMPORTANT: WHEN TIGHTENING LOCK LEVERS (B) AND (C), ALWAYS TIGHTEN LEVER (B) FIRST TO ENSURE TABLE WILL BE LEVEL ON BOTH SIDES.**
2. To lower the table (A) Fig. 21, loosen table lock levers (B) and (C) and while holding table (A) depress spring clip (D) and lower table to the desired setting. Then tighten lock levers (B) and (C). **IMPORTANT: WHEN TIGHTENING LOCK LEVERS (B) AND (C), ALWAYS TIGHTEN LEVER (B) FIRST TO ENSURE TABLE WILL BE LEVEL ON BOTH SIDES.**
3. For fine adjustments to the table setting, loosen table lock levers (B) and (C) Fig. 21, and turn Micro-Set adjustment knob (E) clockwise to raise or counterclockwise to lower the table. Tighten lock levers (B) and (C). **IMPORTANT: WHEN TIGHTENING LOCK LEVERS (B) AND (C), ALWAYS TIGHTEN LEVER (B) FIRST TO ENSURE TABLE WILL BE LEVEL ON BOTH SIDES.**
4. The distance the table surface is positioned below the bottom of the cutter is determined by the pointer (F) Fig. 21, on the dual english/metric scale (G). If an adjustment to the pointer (F) is necessary, loosen screw and adjust pointer accordingly.

TILTING THE TABLE

The table on your machine can be tilted to accommodate workpieces with beveled edges by loosening handle (A) Fig. 22, tilting the table (B) to the desired angle and tightening handle (A). **NOTE:** Handle (A) is spring loaded and can be repositioned by pulling out on the handle and repositioning it on the nut located underneath the hub of the handle.

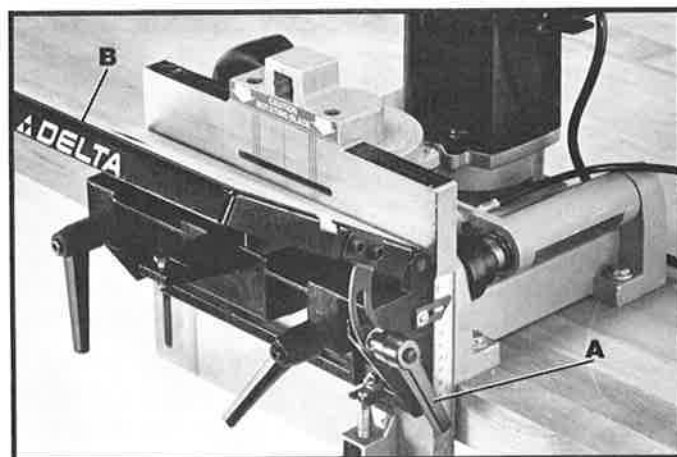

Fig. 22

ADJUSTING TABLE 90 DEGREES TO FENCE

1. Loosen table lock handle (A) Fig. 23, make sure the table is all the way down and tighten lock handle (A).
2. Using a square (B) Fig. 23, check to see if the table is 90 degrees to the fence, as shown.

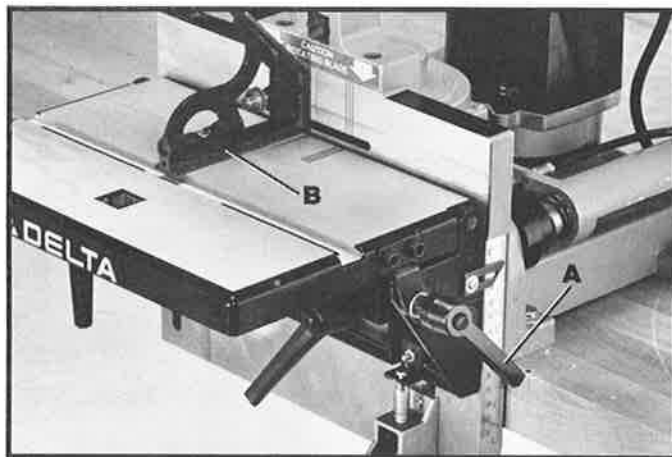

Fig. 23

3. If the table is not at 90 degrees to the fence, adjust the table accordingly making certain screw (C) Fig. 24, contacts bottom of table when the table is at 90 degrees to the fence. Screw (C) can be adjusted by loosening nut (D), turning screw (C) in or out the desired amount and tightening nut (D). This positive stop enables you to rapidly return the table to the 90 degree position after it has been tilted.

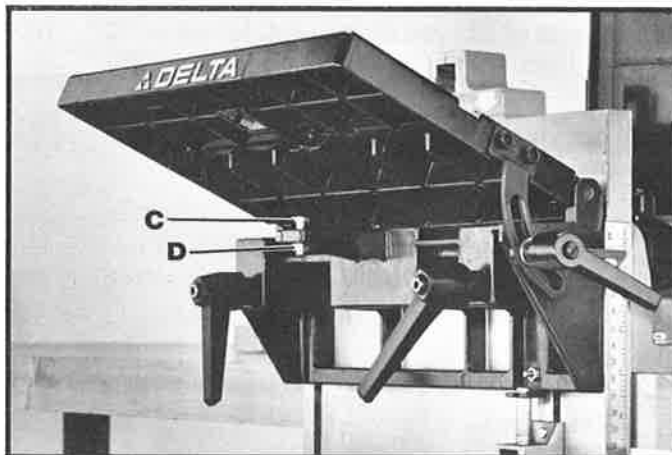

Fig. 24

STARTING AND STOPPING MACHINE

The on/off switch (A) Fig. 25, is located on the side of the motor. To turn the plate joiner "ON," move the toggle switch (A) toward the front. To turn the machine off, push the switch (A) toward the rear.

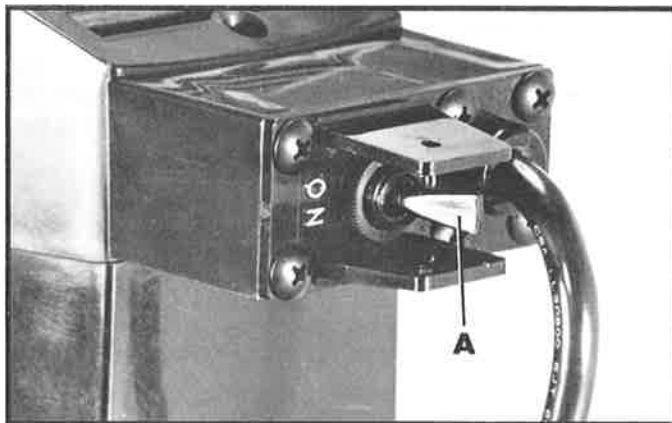

Fig. 25

LOCKING SWITCH IN THE "OFF" POSITION

We suggest when the machine is not in use, the switch (A) be locked in the "OFF" position with a padlock, as shown in Fig. 26.

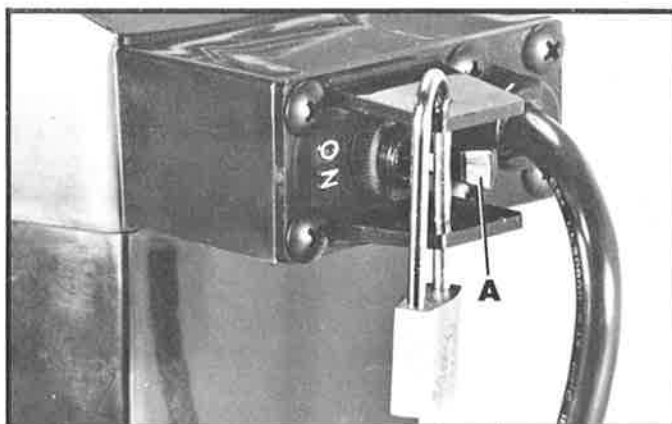

Fig. 26

DEPTH OF CUT CONTROL

The Delta Plate Joiner has the capability of cutting slots in wood to accommodate three biscuit sizes, 0, 10 and 20, as shown in Fig. 27.

The lines (A), (B) and (C) Fig. 27, on the fence and table, indicate the width of cut for each biscuit size:

- (A) - For size "0" biscuit
- (B) - For size "10" biscuit
- (C) - For size "20" biscuit

Line (D) Fig. 27, indicates the center line of the cut to be made for size "0", "10" and "20" biscuits.

To adjust the depth of cut for different size biscuits rotate dial (E) Fig. 28, until the pointer (F) is pointing to the desired size of slot you wish to cut, for either "0", "10" or "20" biscuit.

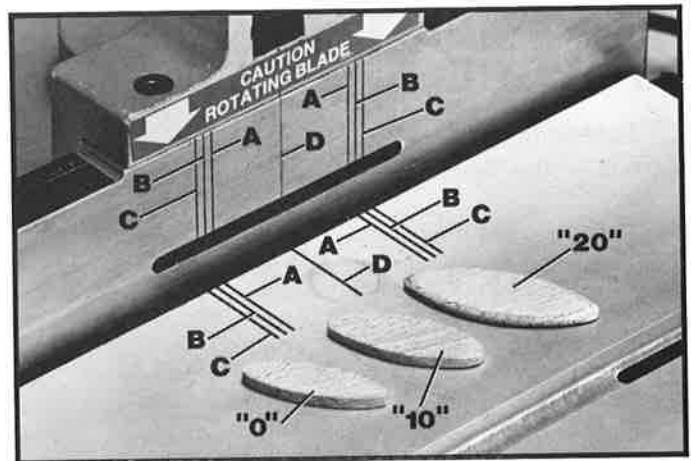

Fig. 27

CHECKING AND ADJUSTING DEPTH OF CUT

1. Rotate dial (E) Fig. 28, until the pointer (F) is pointing to the desired size of slot you wish to cut. **NOTE:** In this case we will be making a test cut for a size "0" biscuit.

2. Make a test cut in a scrap piece of wood.

3. Insert a size "0" biscuit in the cut just made. The biscuit should enter the wood slightly more than halfway before it bottoms in the cut.

4. If the slot is too deep or not deep enough adjust the depth of cut by loosening nut (G) Fig. 28, and tightening or loosening screw (H). Continue to make test cuts until the depth of cut is as stated in **STEP 3**. Then tighten nut (G).



Fig. 28

FOOT PEDAL

The Foot Pedal (A) Fig. 29, controls the lateral movement of the biscuit cutter. Pressing down on the pedal (A) moves the cutter out to make the cut and releasing pedal (A) retracts the cutter.

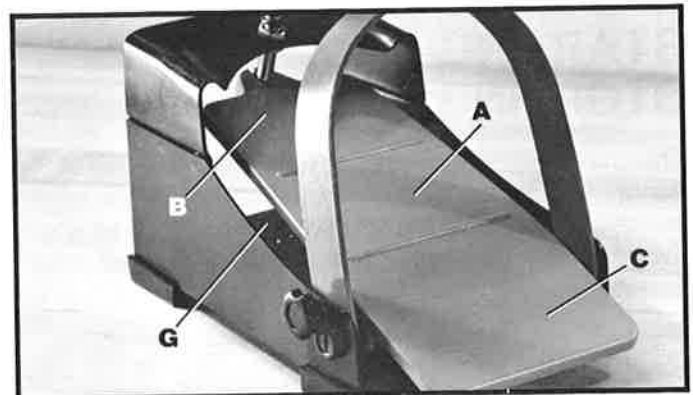

Fig. 29

ADJUSTING FOOT PEDAL CABLE

When the foot pedal (A) Fig. 29, is depressed the bracket (D) Fig. 30, moves forward until the adjusting screw (E) contacts stop (F). When the machine is in this position (cutter exposed on the front of the fence) the boss located directly underneath the top of the foot pedal (B) Fig. 29, should be between 1/4 and 1/2 inch away from bottoming on bottom plate (G) Fig. 29. If it is not, an adjustment to the cable can be made by sliding back sleeve (H) Fig. 30, and adjusting the cable by tightening and loosening the two adjusting nuts (J) and (K) Fig. 30.

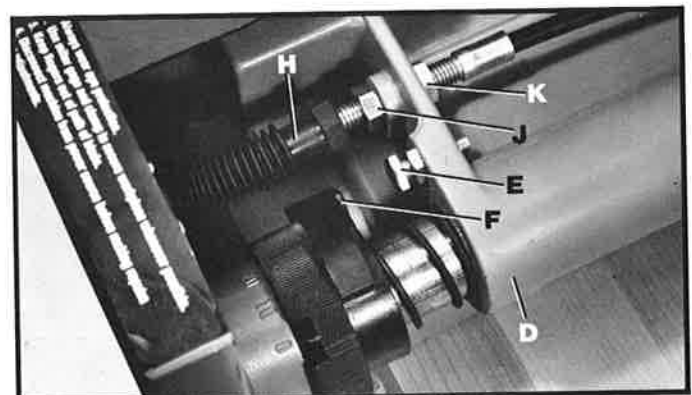

Fig. 30

REPLACING CUTTER

When it becomes necessary to replace the cutter on your plate joiner, proceed as follows:

1. **MAKE CERTAIN THE MACHINE IS DISCONNECTED FROM THE POWER SOURCE.**

2. Remove five screws (A) Fig. 31, and top cutter guard (B).

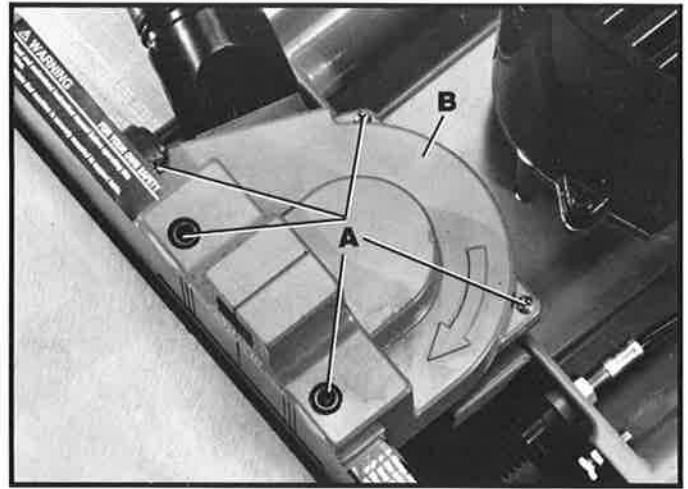

Fig. 31

3. Place open end wrench on flats (C) Fig. 32, of cutter arbor, to keep the arbor from turning, and remove arbor nut (D), flange (E) and cutter (F). **NOTE:** Turn arbor nut (D) clockwise to remove.

4. Assemble new cutter making certain the teeth of the cutter point to the right when looking straight down on the cutter and replace flange (E) and arbor nut (D) Fig. 32. **NOTE:** Turn arbor nut counterclockwise to tighten while holding flats (C) of arbor with wrench to keep arbor from turning.

5. Replace cutter guard which was removed in **STEP 2.**

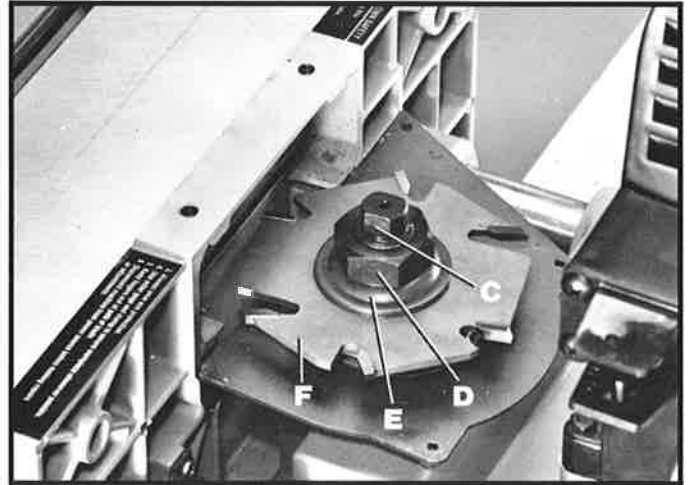

Fig. 32

SOME TYPICAL OPERATIONS

The following are just a few examples of some of the many operations that can be performed with your Delta Plate Joiner. All operators will profit by a knowledge of how these operations can be performed and we suggest you study these examples before turning on the power.

EDGE JOINING

1. Mark the two boards to be edge joined together at the points where the biscuits are to be placed, as shown at (A) Fig. 33. These marks indicate the center of the biscuit cut and should be on the opposite surface of the boards you want perfectly matched. If boards are of different thickness, be sure the "good" or face side of the boards are "down."

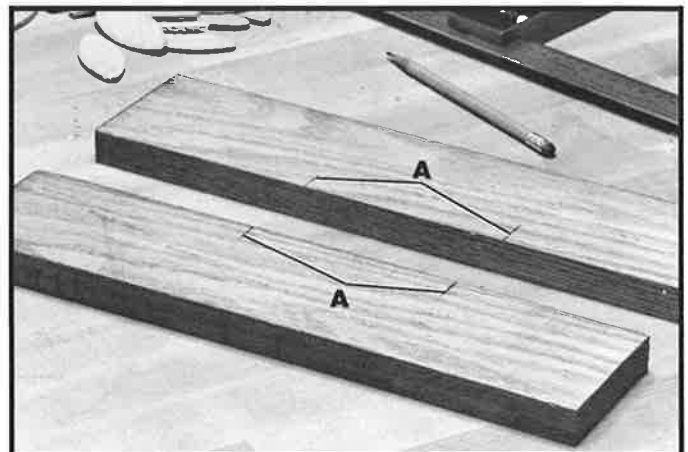

Fig. 33

2. Adjust the height of the table and line up one of the points marked in **STEP 1**, with the center line of the cutter, as shown in Fig. 34, and cut the first biscuit slot. Note the dual position work clamp (B) being used to firmly hold the workpiece on the table. Cut biscuit slots at the remaining three positions that were marked in **STEP 1**.

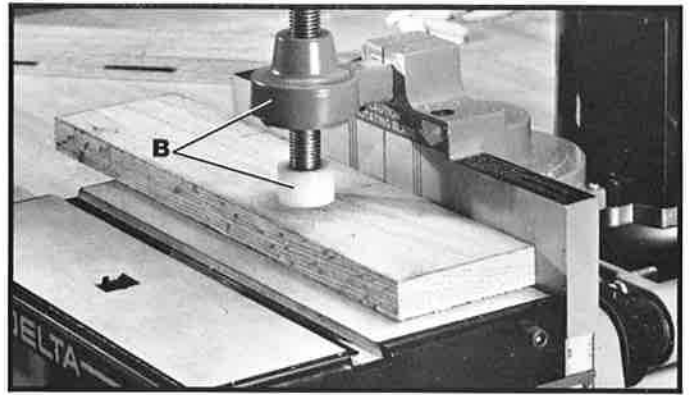

Fig. 34

3. Apply glue to inside of biscuit slots and insert biscuits (C) into two of the slots, as shown in Fig. 35. Then press the two pieces of wood together.

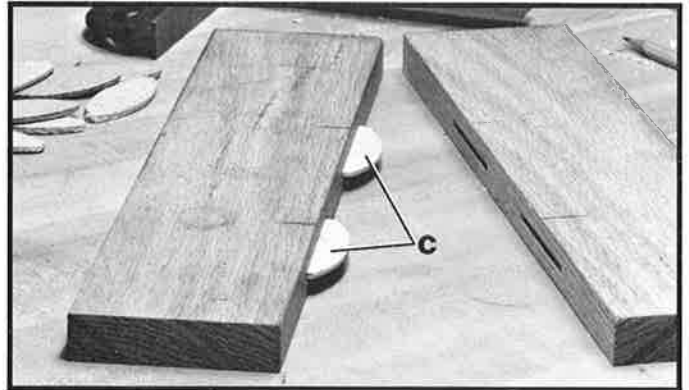

Fig. 35

BEVEL EDGE JOINING

1. Mark the two boards to be bevel edge joined together at the points where the biscuits are to be placed, as shown at (A) Fig. 36. These marks indicate the center of the biscuit cut and should be on the opposite surface of the boards you want perfectly matched.

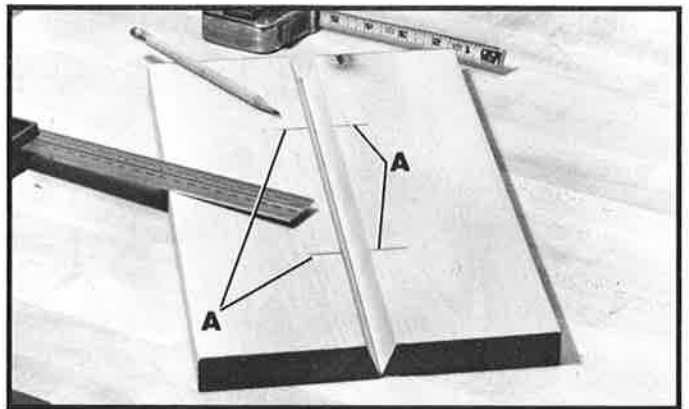

Fig. 36

2. Adjust the angle of the tilting table (B) to match the angle of the workpiece, as shown in Fig. 37. Adjust the height of the table to position biscuit slot at proper location in beveled surface. Line up one of the points marked in **STEP 1**, with the center line of the cutter, and cut the first biscuit slot, as shown. Cut biscuit slots at the remaining three positions that were marked in **STEP 1**.

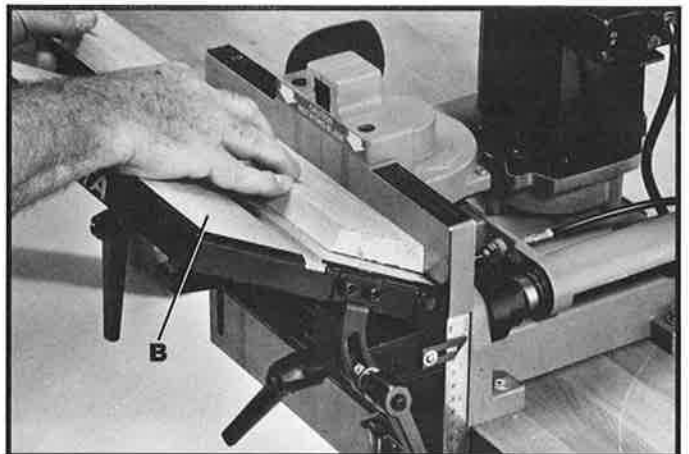

Fig. 37

3. Apply glue to the inside of biscuit slots and insert biscuits (C) into two of the slots as shown in Fig. 38.

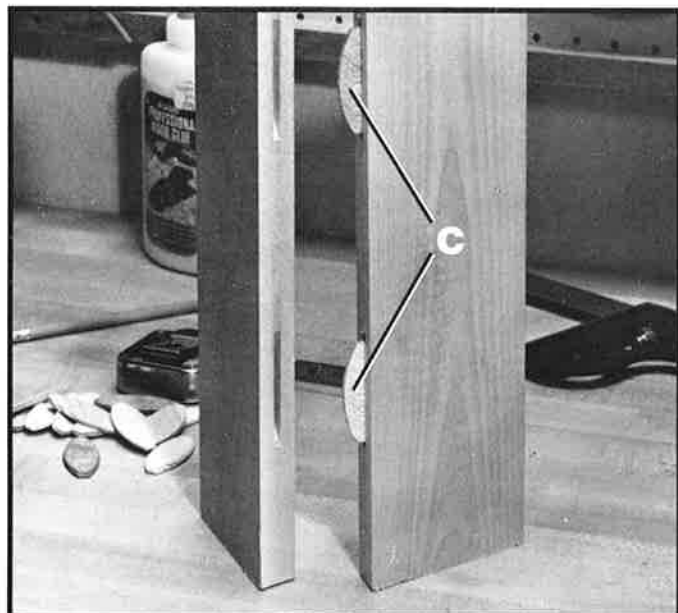

Fig. 38

4. Press the two pieces of wood together as shown in Fig. 39.



Fig. 39

BEVEL END JOINING

1. Mark the two boards to be bevel end joined together at the points where the biscuit is to be placed, as shown at (A) Fig. 40. These marks indicate the center of the biscuit cut and should be on the opposite surface of the boards you want perfectly matched.

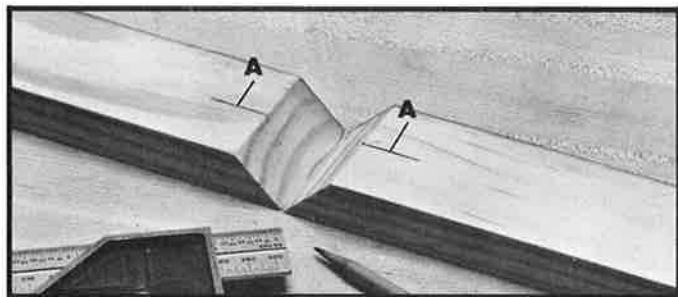

Fig. 40

2. Adjust the angle of the tilting table to match the angle of the workpiece, as shown in Fig. 41. Line up one of the points marked in **STEP 1** with the center line of the cutter and cut the first biscuit slot. **NOTE:** A back-up stop block (B) is clamped to the tilting table to support the workpiece. Cut the biscuit slot at the remaining position marked in **STEP 1**.

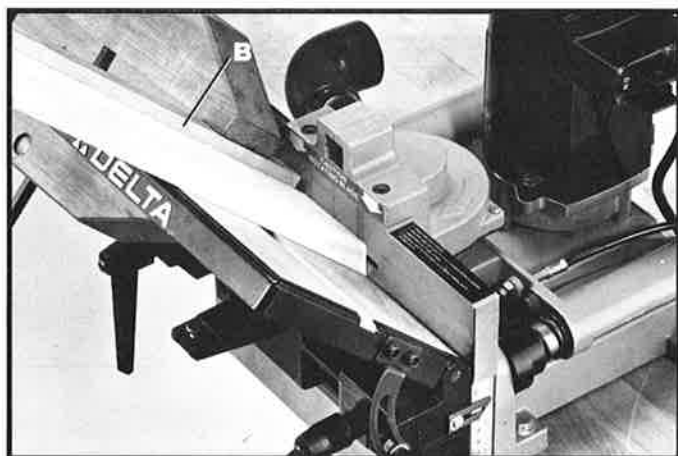

Fig. 41

3. Apply glue to the inside of biscuit slots, insert biscuit and press the two pieces of wood together, as shown in Fig. 42.

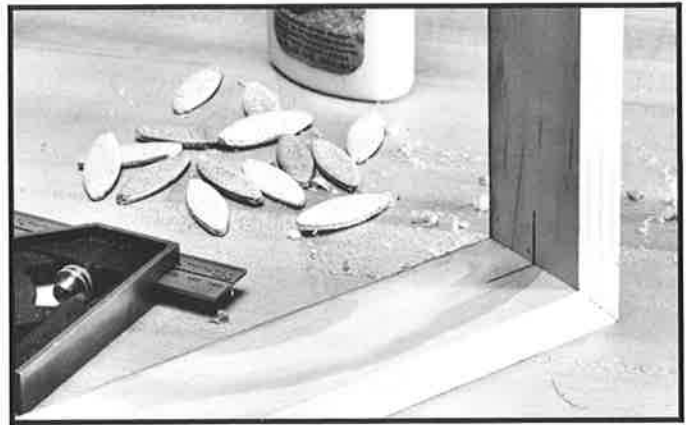

Fig. 42

BUTT JOINING

1. Mark the two boards to be butt joined together at the points where the biscuit is to be placed, as shown at (A) and (B) Fig. 43. These marks indicate the center of the biscuit cut. Make sure the marks (A) and (B) are on the inside surface of the boards as shown. **NOTE:** On the vertical piece the line (B) must extend higher, as shown.

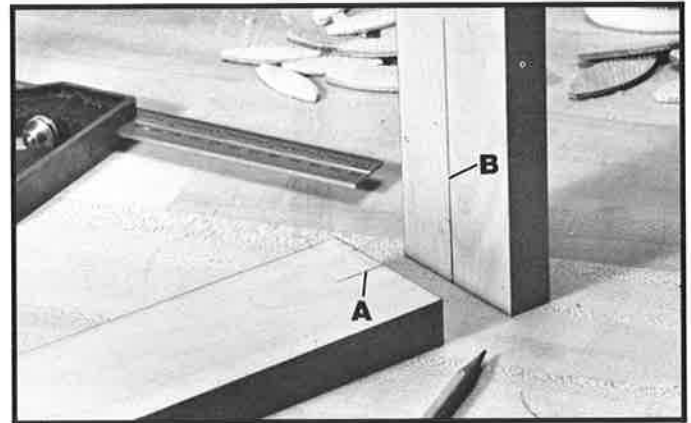

Fig. 43

2. Line up the point marked at (A) in **STEP 1** of the horizontal piece with the center line of the cutter and cut the first biscuit slot, as shown in Fig. 44. Note the dual position work clamp (C) and the adjustable stock stop (D) being used to hold and position the workpiece.

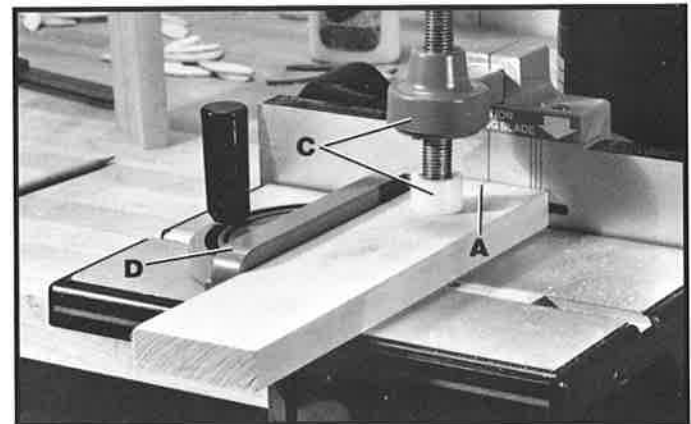

Fig. 44

3. Line up the point marked at (B) in **STEP 1** on the vertical piece with the center line (E) of the cutter and cut the second biscuit slot. This line is located on top of the cutter guard, as shown in Fig. 45. Note the dual position work clamp (C) being used to hold the workpiece.

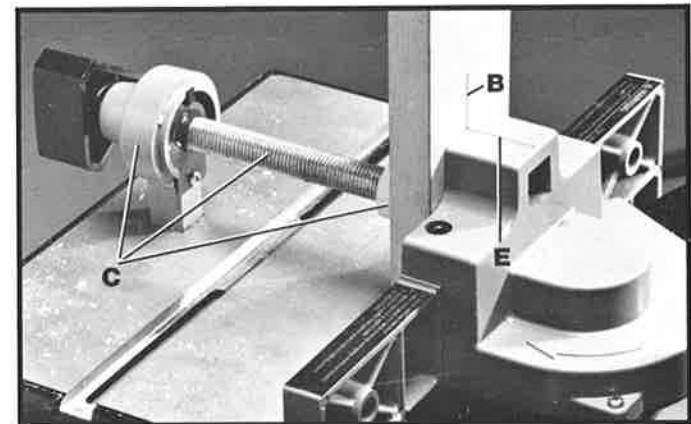

Fig. 45

4. Apply glue to the inside of biscuit slots, insert biscuit (F), as shown in Fig. 46, and press the two pieces of wood together.

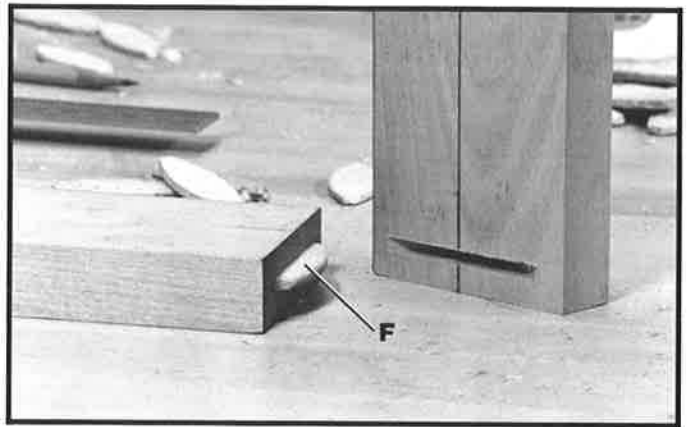

Fig. 46

MITER JOINING

1. Adjust the angle of the stock stop (A) Fig. 47, to conform with the miter angle of the workpiece, center the workpiece over the cutter slot, clamp the stock stop to the table and cut the biscuit slot in the first piece, as shown in Fig. 47. Note that “good” or face side of the board is against the table.



Fig. 47

2. Cut the biscuit slot in the second piece, as shown in Fig. 48, in the same manner as in **STEP 1** with the “good” or face side of the board against the table.

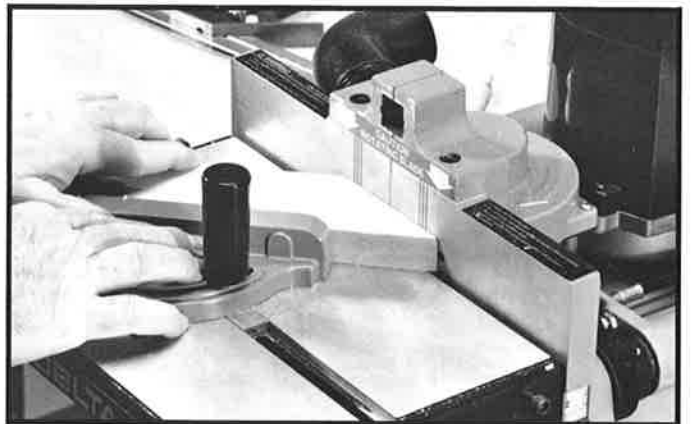

Fig. 48

3. Apply glue to the inside of biscuit slots, insert biscuit and press the two pieces of wood together, as shown in Fig. 49.

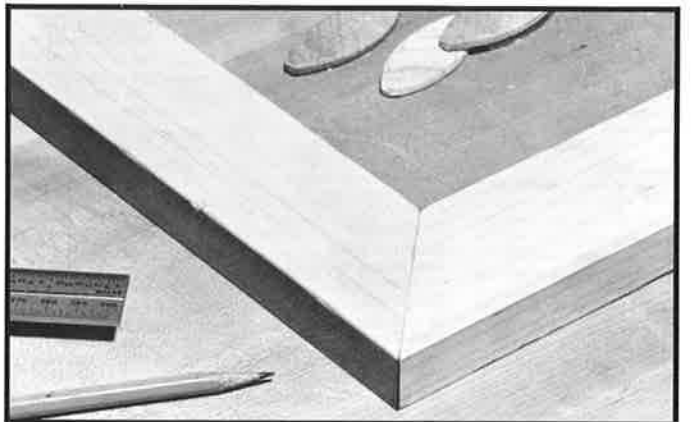

Fig. 49

AUTHORIZED SERVICE STATIONS

In order to promote tool safety, Delta International Machinery Corp. strictly enforces the policy of repairing or replacing any damaged or missing standard safety equipment on machines presented to Delta Authorized Service Centers for service/repairs. Any product which is presented to a Delta Authorized Service Center for repairs which contains missing or damaged standard safety equipment will have that equipment repaired or replaced and the customer will be charged for any such service/repairs. Customers can avoid such charges only if the missing safety component is supplied to the service center at the time of repair.

ALABAMA Birmingham 35209 Porter-Cable Corporation 131 W. Oxmoor Rd., Suite 105 205-942-6325 Montgomery 36121 Nor Wood Industries, Inc. 581-A George Todd Drive 205-260-9663 Mobile 36606 Power Tool Service of Mobile 729 Holcombe Avenue 205-479-9832	Los Angeles 90004-5905 California Electric Service 140 S. Vermont Avenue 213-388-9651 Fax: 213-388-8577 Los Angeles 92203 Minit Tool Company 3026 E. Olympic 213-264-7006 Mission Viejo 92691-3128 California Electric Service 23725 Via Fabricante, Unit B 714-586-9440 Fax: 714-586-9514 Modesto 95351 Stanislaus Electric Mtr. Wrks. 504 River Road 209-523-8269 National City 92050 Nall, Tool & Machy. Repair, Inc. 241 W. 35th St. STE D 619-422-8665 North Hollywood 91605 Bucknall Power Tool Service 11910 Vose Street 818-765-0228 Oakland 94606-4389 California Electric Service 1139 E. 12th Street 415-834-1050 Fax: 415-836-1125 Oceanside 92054 Power Source 1555 S. Hill Street 619-433-6600 Pasadena 91107-3785 California Electric Service 2594 E. Colorado Blvd. 818-792-3194 Fax: 818-792-0511 Redding 96002 Electric Tool and Motor 915 Wall Street #1 916-222-1131 Sacramento 95814-6784 California Electric Service 1821 "Q" Street 916-443-5711 Fax: 916-443-4092 Sacramento 95814 Construction Industry Service Company 1211 C Street 916-444-2525 San Carlos 94070-4168 California Electric Service 990 Industrial Road, Suite 102 415-593-6696 Fax: 415-593-6698 San Diego 92104-1593 California Electric Service 3430 El Cajon Blvd. 619-283-6488 Fax: 619-281-3479 San Francisco 94103-4488 California Electric Service 1090 Bryant Street 415-431-8494 Fax: 415-431-9207 San Jose 95126-3154 California Electric Service 783 The Alameda 408-295-1723 Fax: 408-295-8451 San Leandro 94577 Porter-Cable Corporation 3039 Teagarden Street P.O. Box 1913 415-357-9762 San Marcos 92069 Pro-Tek Tool Repair 215 Pacific Street, #111 619-471-4800 Santa Ana 92707-2850 California Electric Service 2025 S. Main Street 714-641-0529 Fax: 714-641-2947 Santa Rosa 95401 Acme Electric Tool Repair 742 Wilson Street 707-546-5862 Santa Rosa 95403 H & V Tool Repair 1808 Empire Industrial Court #D 707-528-1111 Simi Valley 93065 Simi Tool Repair 1236 Los Angeles Avenue, Unit D 805-584-8138	Temecula 92390-5623 California Electric Service 41715 Enterprise Circle North Suite 101 714-695-5445 Fax: 714-695-5447 Torrence 90502 Universal Tool Service 21804 S. Vermont Avenue 213-328-6472 Van Nuys 91411-1018 California Electric Service 14753 Oxnard Street 818-997-8855 Fax: 818-997-3047 Whittier 90602 Balleis Hdw & Tool Co. 13238 E. Whittier Blvd. 213-698-3714 W. Los Angeles 90064-2110 California Electric Service 2314 S. Westwood Blvd. 213-475-2532 Fax: 213-475-2844 COLORADO Avon 81620 Tool Clinic 41000 Highway 6 303-949-6282 Colorado Springs 80219 Schlosser Tool and Machinery 3960 Sintlon Road 719-636-1311 Denver 80204 Porter-Cable Corporation 2561 West 8th Ave. 303-892-6113 Denver 80219 "Schlosser Tool and Machinery 301 Bryant Street 303-922-8244 Grand Junction 81501 Professional Tool Service, Inc. 124 22nd Ct. 303-245-3158 CONNECTICUT Hartford 06106 Utility Electric Service, Inc. 53 Main Street 203-246-7271 Oakville 06779 Watertown Tool Supply 28 Main Street 203-596-1344 DELAWARE New Castle 19804 Holloway Bros. 19 E. Commons Blvd. 302-322-5441 "Wilmington 19804 Holloway Bros. P.O. Box 3055 302-322-5441 FLORIDA Ft. Lauderdale 33334 Master Repair Inc. 4107 N.E. 6th Avenue 305-566-5833 Fl. Myers 33905 Power Tool Repair of Fl. Myers 9950 Orange River Blvd. 813-894-6058 Gainesville 32609 Florida Fastener and Tool Co., Inc. 2826 N. Waldo Road 904-377-4587 Hialeah 33014 Porter-Cable Corporation 16373-75 NW 57th Ave. 305-824-2523 Jacksonville 32205 North Florida Machinery & Tool Repair 230-B Edgewood Ave. South 904-987-4455 Orlando 32803 Finch's Machinery & Tool Service Inc. 1807 1/2 Winter Park Road 407-644-8100 Pensacola 32505 L. C. Electric Motor Service 117 Industrial Blvd. 904-476-7655 Riviera Beach 33404 3706 E. Industrial Way 407-848-4320 Tampa 33609 Porter-Cable Corporation 4538 W. Kennedy Blvd. 813-877-9585	West Palm Beach 33409 Rogers Engines Inc. 2532 Old Okeechobee Road 407-689-8300 GEORGIA Augusta 30901 Tool Service Center Box No. 1488 302 Walton Way 404-724-4803 Morrow 30260 Porter-Cable Corporation 1286C Citizens Parkway 404-961-0900 Savannah 31402 Morgan's 110 Ann Street 912-234-2271 HAWAII Hilo 96720 Hawaii Planning Mill Ltd. 380 Kanoolehua Avenue 808-935-0875 Honolulu 96819 A.L. Kilgo Co., Inc. 180 Sand Island Road 808-832-2200 Honolulu 96819 Slim's Power Tools, Inc. 1626 Republican Street 808-841-0902 Honolulu 96817 John Grinnon Co., Inc. 345 N. Nimitz Hwy. 808-538-7333 Kahului 96732 Maui Power Tool Service 251-H2 Lalo Street 808-877-3440 IDAHO Boise 83705 Air Equipment Company 2350 South Orchard Street 208-375-1313 Boise 83706 K. C. Supply Co. 5103 Irving Street 208-375-1313 Coeur d'Alene 83814 Coeur d'Alene Tool 451 Cherry Lane & Hwy 95 208-667-1158 Idaho Falls 83403 Rossiers Electric Motor 1501 South Capital Avenue 208-529-3665 Twin Falls 83301 Ellis Repair 2380 Kimberly Road 208-734-4400 ILLINOIS Addison (Chicago) 60101 Porter-Cable Corporation 311 Laura Drive 708-628-6100 North Pekin 61554 Central Tool & Equip. Div. A & I Supply 97 Highway Blvd. 309-382-2400 Springfield 62702 James Machinery 223 N. MacArthur 217-522-9115 INDIANA Elkhart 46516 Thunander Corporation 21861 Protecta Dr. 219-295-4131 Evansville 47711 Tri State Repair Service 1327 N. Fares 812-464-9341 607-729-5287 Fort Wayne 46808 Merrick Evans Inc. 2116 W. Coliseum Blvd. 219-482-4822 Goshen 46526 C & L Electric Motor Repair 1405 Chicago Avenue 219-533-2643 Indianapolis 46241 Macco Equip. Co., Inc. 3129 Kentucky Avenue 317-248-1444 Valparaiso 46383 Airmaster, Inc. 152 Appletree Lane 219-477-5495	IOWA Cedar Rapids 52404 Puckett Tool & Fastener 410 1st Avenue NW 319-363-2211 Davenport 52803 Industrial Engineering Equipment Co. 1958 River Street 319-323-9721 Des Moines 50309 Puckett Electric Tools, Inc. 841 11th Street 515-244-4189 Hiawatha 52233 Janda's Tool Center 754 N. Center Point Road 319-393-4740 Sioux City 51107 Tools 'N' More 606 Cunningham Dr. 712-258-7921 KANSAS Salina 67401 Mid Kansas Tool Repair 314 W. Cloud 913-825-6287 Wichita 67213 Richmond Electric Co. 911 Maple 316-264-2344 KENTUCKY Lexington 40505 Kwik-Set Fasteners, Inc. 1151 Commercial Drive 606-252-7518 Louisville 40219 Ball Bros. Machine & Tool Repair 8109 Preston Highway 502-969-1626 Louisville 40206 Bargain Supply Company 844 E. Jefferson Street 502-582-6651 Louisville 40217 Tool Repair Service 1200 Goss Avenue 502-635-6888 LOUISIANA Baton Rouge 70806 Baton Rouge Rental Service 5101 Government Street 504-924-2959 Metairie 70011 R.J. Marchand Cont'r. Spec., Inc. P.O. Box 8148 3515 Division Street 504-888-2922 New Orleans 70153-3432 Beerman Precision, Inc. P.O. Box 53432 4206 Howard Avenue 504-486-9391 Shreveport 71101 McClamroch Machinery 939 Louisiana Avenue 318-222-9249 MAINE Bangor 04401 N.H. Bragg & Son Box 927, 92 Perry Rd. 207-947-8611 Portland 04104 M and W Tool Service 38 Portland Street 207-772-2057 MARYLAND Baltimore 21201 Porter-Cable Corporation 7397 Washington Blvd. Suite #102 301-799-9394 Fax: 301-799-9398 Baltimore 2101 "Skarie, Inc. 707 N. Howard Street 301-728-6000 Cumberland 21502 Allegheny Motor & Pump Service 150 Wineow Street 301-777-0340 MASSACHUSETTS Boston (Allston) 02134 Porter-Cable Corporation 414 Cambridge Street 617-782-1700 Fall River 02721 Burns, Inc. 350 M.S. Bishop Blvd. 617-675-0381	Franklin 02038 Porter-Cable Corporation 101-E Constitution Blvd. 508-520-8802 Fax: 508-528-8089 Springfield 01105 Saw Center 472 Main Street 413-734-2045 MICHIGAN Gladwin 48624 "Tool Haus 630 N. Silver Leaf 517-426-4549 Petoskey 49770 Ed's Electric Appliance Service 3924 Charlevoix Rd. 616-347-9599 Southfield (Detroit) 48075 Porter-Cable Corporation 18650 W. Eight Mile Road 313-569-4333 Traverse City 49684 Davis Electric Inc. 1131 Hastings Street 616-947-9860 MINNESOTA Minneapolis 55429 Porter-Cable Corporation 4315 68th Avenue North 612-561-9080 MISSISSIPPI Hattiesburg 39404 Mitchell Power Tool Service 2000 Byron Street 601-264-3308 Jackson 39202 Flannigan Electric Co., Inc. 1820 S. West Street Ext. 601-354-2756 MISSOURI Joplin 64802 Electric Motor Supply Inc. P.O. Box 1925 2301 West 20th Street 417-623-4544 North Kansas City 64116 Porter-Cable Corporation P.O. Box 12393 816-221-2070 St Louis 63119 Porter-Cable Corporation 7574 Watson Road 314-968-8950 Springfield 65802 Middle Earth Tool Repair, Inc. 306 No. National 417-831-0954 MONTANA Billings 59101 Allen's Electric Tool Repair 431 St. John's Avenue 406-248-3865 Black Eagle 59414 Mosch Electric Motors 2513 17th Street North 406-453-2481 Missoula 59801 City Electric Electro Service Center Div. 101 S. Catlin Street 406-549-4115 Missoula 59801 Montana Tool Co. 1908 North Ave. West 406-721-6425 NEBRASKA Lincoln 68504 Lincoln Tool Service Center 3535 North 40 402-464-1157 Omaha 68127 Thacker Electric 8507 I Street 402-592-9433 NAT WATS 800-678-7604 Omaha 68127 Tool Hospital 4630 So. 85 Street 492-592-5220 NEVADA Las Vegas 89103 E & M Industrial Hdw. 3725 West Russell Rd. 702-736-6102 Las Vegas 89118 All Tools Repair 5720 S. Valley View #5 702-736-6102
---	---	---	---	--	--

Authorized Service Stations (continued)

- Las Vegas 89109
Tool Service, Inc.
3229 Industrial Road
702-734-9161
- Reno 89512
Comstock Electric
425 Eureka Avenue
702-323-5982
- NEW HAMPSHIRE**
Brentwood 03833
Brentwood Machine Sales Inc.
Building #313 - Rte #125
603-679-8452
- Keene 03431
Hamshaw Lumber
3 Bradco Street
603-352-6506
- Keene 03431
Monadnock Tool Source
415 Marlboro Street
603-357-7620
- Nashua 03061
Hammer Industrial
175 Amherst St.
P.O. Box 1209
603-892-5161
- NEW JERSEY**
Somerville 08876
Butensky Services Co.
10 County Line Road, Suite 7
908-707-0912
- Union 07083
Porter-Cable Corporation
945 Ball Avenue
201-964-1730
- NEW MEXICO**
Albuquerque 87107
Martin Saw and Tool
3421 Vassar N.C.
505-898-1675
- Albuquerque 87108
J-M Tool Repair Co.
320 Florida S.E.
505-255-2304
- NEW YORK**
Albany 12206
Albany Burner Control, Inc.
20 Colvin Avenue
518-459-8856
- Amherst 14226
*Phillips Bros. Supply Inc.
2525 Kensington Avenue
716-839-4800
- Buffalo 14210
SS Electric Repair Shop Inc.
2470 Seneca Street
716-823-1232
- Commack 11725
*County Power Tool Service, Inc.
237 Commack Rd.
516-499-5666
- Flushing 11365
Porter-Cable Corporation
175-25 Horace Harding Expwy.
718-225-2040
- Glens Falls 12801
J. E. Sawyer
64-90 Glen Street
518-793-4104
- Kingston 12401
Miron Bldg. Products, Inc.
C.P.O. Box 1598
Rt. #9W North
914-336-6000
- Peekskill 10566
Peekskill Electric Motor
13 South Broad St.
914-737-4141
- Port Chester 10573
Pelham Tool Co.
21 Abendrough Avenue
914-937-1771
- Rensselaer 12144
R. B. Wing
83 Second Avenue
518-463-4161
- Rochester 14608
Jackson Saw & Knife Co.
517 State Street
716-546-7485
- Rochester 14609
O. G. Schwarz
430 Allamantic Avenue
716-482-9282
- Southampton 11968
Richards Tool and Motor Repair
County Road 39 & N. Main Street
516-283-5130
- Syracuse 13220
Mid-State Contractors
1811 LeMoine Avenue, Box 2189
315-455-5903
- Syracuse 13210
Syracuse Industrial Sales
713 E. Fayette Street
315-478-5751
- Uniondale 11553
*Enterprise Machinery Co., Inc.
293 Nassau Road
516-485-2804
- Ulita 13502
McQuade and Bannigan
1300 Stark Street
315-724-7119
- Vestal 13850
Cascade Electric Inc.
416 Commerce Rd.
607-729-5278
- Watertown 13601
McQuade & Bannigan
124 Murdock Circle
315-789-2612
- NORTH CAROLINA**
Burlington 27215
Paynes Power Tool
2550 S. Mebane Street
919-227-1031
- Charlotte 28209
Porter-Cable Corporation
4303B South Boulevard
704-525-4410
- Foscoe 28604
Action Power Tools
Hwy. 105
704-963-7271
- Greensboro 27405
Tool & Equipment Supply, Inc.
807 Huffman Street
919-275-6124
- Raleigh 27604
Specially Tool Service of Raleigh, Inc.
2420 Atlantic Ave.
919-833-5903
- Wilmington 28401
Coastal Power Tool and Equipment
Repair
1913 Carolina Beach Road
919-762-0777
- Wilmington 28405
M. F. McLean Enterprises
Rt. 6, Box 97
Old Wrightsville Road
919-343-1775
- Winston Salem 27106
Piedmont Power Mach. Srv. Inc.
4305J Enterprise Drive
919-759-2022
- NORTH DAKOTA**
Bismark 58501
Acme Electric Motor, Inc.
1009 Basin Avenue
701-258-1267
- Fargo 58103
Acme Electric Motor, Inc.
3401 Interstate Blvd.
701-235-8060
- Grand Forks 58201
Acme Electric Motor, Inc.
1705 13th Avenue North
701-746-6481
- Minot 58701
Acme Electric Motor, Inc.
525 20th Avenue S.E.
701-839-2263
- OHIO**
Barberton 44203
Viking Akron Tool & Supply Co.
2915 New Park Drive
1-800-362-0585
216-753-1063
- Cincinnati 45210
Cincinnati Electric Repair
2023 Elm St.
513-621-2183
- Cincinnati 45245
Pro Tool Service
747 Ohio Pike
513-753-4349
- Cincinnati 45215
Pro Tool Service Inc.
1125 Glendale-Milford Road
513-772-1490
- Columbus 43212
*Columbus Hardware
944 W. 5th Avenue
614-294-8665
- Columbus 43214
Porter-Cable Corporation
4560 Indianola Avenue
614-263-0929
- Alpha (Dayton) 45301
Authorized Tool Service Co.
676 Orchard Lane
P.O. Box 5
513-429-5593
- Hartsville 44632
Hartville True Value
940 W. Maple Street
216-877-3631
- North Canton 44720
N. Canton Repair Shop
1555 No. Main
216-499-3529
- Toledo 43606
Power Tool Sales & Service
2934 Douglas Road
419-473-0962
- Toledo 43613
Electric Tool & Equipment
3156 Upton Avenue
419-474-7537
- Valley View 44125
Porter-Cable Corporation
Sweet Valley Business Park
Unit #18
216-447-9030
- West Milton 45383
Conken Equipment Co.
4950 Frederick Garland Road
513-698-3363
- Youngstown 44512
Moff Master Power Tools
5228 Market Street
216-783-2130
- OKLAHOMA**
Oklahoma City 73126
Whitton Supply Co.
1419 W. Reno
405-236-5561
- Tulsa 74101
Wesche Company
P.O. Box 217
2005 East 7th Place
918-583-7551
- OREGON**
Eugene 97402
Jim's Tool Service
515 Wilson Street
515-344-1513
- Klamath Falls 97601
Quality Tool Repair
836 Richmond Street
503-883-5870
- Medford 97501
Precision Power Tool
Repair Inc.
2919 N. Pacific Highway
503-770-5541
- Portland 97202
Professional Power Tool Repair, Inc.
2506 S.E. 8th Ave.
503-234-3734
- Portland 97212
Continental Machine &
Tool Inc.
51 N.E. Hancock
503-288-8888
- Redmond 97756
Dave's Tool Repair
2392-S. Highway 97
503-548-0510
- PENNSYLVANIA**
Allentown 18103
Curio Electric Repair
825 South 5th
215-432-9923
- Bellefonte 16823
*Triangle Bldg. Supply & Services
1076 E. Bishop St.
814-355-5885
- Harrisburg 17109
Stationary Equipment Sales
& Service
P.O. Box 10242
Rear 3805 Ridgeway Rd.
717-545-8043
- Kingston 18704
Total Services & Systems, Inc.
166 W. Union Street
717-287-2121
- Monroeville 15146
Professional Tool Service
700 Seco Road
Monroeville Industrial Park
412-373-7440
- Philadelphia 19107-2375
Ideal Tool & Equipment Service
140 N. 10th Street
215-925-0672
- Philadelphia 19154
Porter Cable Corporation
12285 McNully Road
215-677-7800
Fax No.: 215-677-9908
- Slatingsport 18080
Doward's Electric
4711 Main Street
215-767-8148
- York 17402
Diamond Air & Electric
2449 S. Queen St.
717-741-9592
- SOUTH CAROLINA**
Columbia 29203
Mann Electric Repair Co.
3600 Main Street
803-252-7777
- Greenville 29602
Poe Corporation
P.O. Box 168
803-271-9000
- Mt. Pleasant 29464
Royal Ace Hardware
884 Ben Sawyer Blvd.
803-884-2552
- Myrtle Beach 29577
Coastal Elec. & Rewinding
718 8th Avenue N.
803-448-3566
- Spartanburg 29302
Cash Supply
113 Country Club Rd.
803-585-9326
- SOUTH DAKOTA**
Rapid City 57702
Stan Houston Equipment Co.
1210 Deadwood Avenue
605-348-1155
- Sioux Falls 57202
Stan Houston Equip. Co.
501 S. Marrion Road
605-336-3727
- TENNESSEE**
Chattanooga 37412
F & D Tool Service and Supply
4121 Ringgold Road
615-698-6454
- Clarksville 37043-5153
Triple S Industries
1511A Vista Lane
615-648-8665/615-648-9288
- Jackson 38301
Smith Tool Service
908 S. Highland Avenue
901-427-4012
- Jamestown 38556
Kirby's Fix-It
P.O. Box 147, 120 N. Norris
615-879-7414
- Knoxville 37914
Adrian Machine Tools
2900 Thorn Grove Pike
615-522-9991
- Knoxville 37918
Shop Equipment Service Co.
4821 N. Broadway
615-688-3574
- Memphis 38106
Power Tools, Inc.
1200 S. Bellevue
901-774-1212
- Memphis 38115
Bird Fasteners, Inc.
6920 Winchester Rd., #102
901-366-1748
- Nashville 37210
Allied Tool Repair
1005 Second Ave. S.
615-242-8026
- Nashville 37210
Power Tool Service of
Nashville, Inc.
1106 Elm Hill Pike
Suite #130
615-255-8227
- TEXAS**
Ablene 79604
Ablene Lumber Co., Inc.
2025 Industrial Blvd.
Amarillo 79109
Builder's Tool Service
2705 Virginia Circle
806-352-1772
- Austin 78722
Hamilton Electric Works Inc.
3800 Airport Blvd.
512-472-2428
- Austin 78758-5498
The Tool Box
9906A Gray Boulevard
512-836-5483
- Corpus Christi 78405
Corpus Christi Power Tool
& Repair
3701 Aghes
512-883-1117
- Corpus Christi 78405
Otto Dukes Machinery Co.
2588 Morgan Street
512-883-0921
- Dallas 75220
Porter-Cable Corporation
10714 N. Stemmons Freeway
214-353-2996
- El Paso 79902
Schlosser Tool & Machinery
1505 Wyoming
915-544-8665
- El Paso 79905
C. L. North Co.
123 Chelsea Street
915-772-1469
- Fl. Worth 76110
Air & Electric Tool Co., Inc.
3301 South Grove
817-921-0231
- Houston 77008
*Circle Saw Builders Supply
2510 Ella Boulevard
713-864-8444
- Houston 77092
Porter-Cable Corporation
5201 Mitchelldale, Suite B-9
713-682-0334
- Longview 75606
Eastex Welding
Box 3223, 1232 W. Marshall
214-758-7327
- Lubbock 79405
Lubbock Electric Co.
1108 34th Street
806-744-2336
- San Angelo 76903
Frank's Electric
2621 Martin Luther King
915-655-8928
- San Antonio 78205
Electric Motor Service
1514 E. Commerce
512-226-3462
- San Antonio 78212
*Otto Dukes Machinery
600 San Pedro
512-224-5576
- Sherman 75090
Texoma Tool Repair Co.
309 E. Houston Street
214-892-1510
- Texarkana 75501
Ray's Electric Motor Repair
922 Bowie Street
214-792-7031
- Tyler 75702
Mason Machinery
1908 W. Erwin Street
214-592-6581
- Waco 76710
Gross Yowell
3720 Franklin Drive
817-754-5425
- Weslaco 78596
Weslaco Tool Co.
316 E. 4th Street
512-968-9156
- Wichita Falls 76307
Bond Tool Company
P.O. Box 32
817-322-5343
- UTAH**
Logan 84321
Tool Liquidator
839 N. Main
801-753-4256
- Salt Lake City 84115
A.C. Tool and Service, Inc.
2990 South West Temple
801-487-4953
- Salt Lake City 84115
*M & M Tool and Machinery
1773 S 300 W (Rear)
801-485-8200
- VERMONT**
S. Burlington 05403
Burlington Tool Repair
23 San Remo Drive
802-658-4131
- VIRGINIA**
Charlottesville 22901
Allen Desper Repair Service
P.O. Box 1612
1132 E. Market Street
804-293-7913
- Fredericksburg 22404
Fredericksburg Hardware Co., Inc.
513 William Street
703-373-8383
- Harrisonburg 22801
Rocking R Hardware
1030 S. High Street
703-434-9967
- Newport News 23606
National Tool Supplies
806 Middle Ground Blvd.
804-873-1115
- Norfolk 23517
Bryan Electric Co., Inc.
424 West 25th Street
804-625-0378
- Norfolk 23502
*Henry Walke Co.
1161 Ingle Side Road
804-855-0502
- Richmond 23230
Southland Power Tool Srv.
1705 Dabney Road
804-257-7348
- Roanoke 24013
Roanoke Armature Co.
1108 1/2 Street S.E.
703-345-8741
- WASHINGTON**
Renton 98055
Porter-Cable Corporation
268 Southwest 43rd Street
206-251-6880
- Spokane 99202
Spokane Power Tool
E. 801 Trent Avenue
509-489-4202
- Tacoma 98424
Tap Power Tool Service
1401 52nd Avenue, East
206-922-1803
- Yakima 98901
Cooper Electric Motor Service
205 S. 4th Avenue
509-452-9550
- WEST VIRGINIA**
Huntington 25701
Lawter Electric Motor Co.
202 Adams Avenue
304-522-8297
- Wheeling 26003
Kennedy Hardware
3300 McCulloch Street
304-233-3600
- WISCONSIN**
Green Bay 54301
Power Tool Service Co.
310 N. Webster Ave.
P.O. Box 1343
414-437-2594
- LaCrosse 54603
A-Line Machine Tool Co.
800 Monitor St.
608-785-1515
- Madison 53713
Electric Motors Unlimited
1000 Jonathan Drive
608-271-2311
- Milwaukee 53222
Porter-Cable Corporation
10700 W. Burtleigh Street
414-774-3650
- Oshkosh 54901
*Kiltz & Pfeil Hardware
427 North Main
414-236-3340
- Wausau 54401
R.A. Miller Supply
1109 McCleary Street
715-842-9189
- WYOMING**
Casper 82601
Casper Saw Shop
147 S. McKinley
307-237-3279
- PUERTO RICO**
Sierra Bayamon 00619
B & M Electric Tool
Repair Center
Calle 49, Bloque 51
Casa 27 Avenue West Main
809-787-2287
- CANADA**
Alberta
Calgary T2H 2L7
#10 6320 11th St. S.E.
403-255-3530
- British Columbia
Burnaby V5A 4T8
8520 Baxler Place
604-420-0102
- Manitoba
Winnipeg R3H 0H2
1699 Dublin Avenue
204-633-9259
- Ontario
Mississauga L4V 1J2
6463 Northam Drive
416-677-5330
- Guelph N1H 6M7
644 Imperial Road
519-836-2840
- Ottawa K2A 3X2
851 Richmond Road
613-728-1124
- Quebec
St. Laurent
(Montreal) H4N 1W2
523 Rue Deslauriers
514-336-8772
- Ste. Foy G1N 4L5
Suite 202
2202 Rue Lavoisier
418-681-7305

*IND. MACHINERY SERVICE



PARTS, SERVICE OR WARRANTY ASSISTANCE

All Delta Machines and accessories are manufactured to high quality standards and are serviced by a network of factory service centers and authorized service stations listed in your owner's manual. To obtain additional infor-

mation regarding your Delta quality product or to obtain parts, service or warranty assistance, please call or fax Delta's toll-free 'hotline' number.

Delta maintains a modern, efficient Parts Distribution Center, maintaining an inventory of over 15,000 parts located in Memphis, Tennessee.

Highly qualified and experienced Customer Service Representatives are standing by to assist you on weekdays from 8:00 A.M to 5:00 P.M. Memphis time.

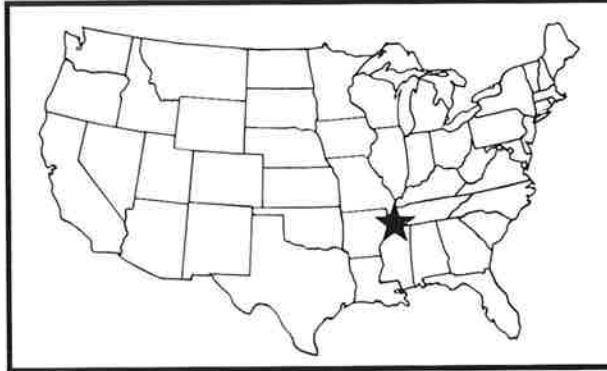

Memphis, TN 38118
4290 Raines Road
Phone: (901) 363-8800

HOTLINE
800-223-PART
FAX: 800-535-6488



Delta Building Trades and Home Shop Machinery Two Year Limited Warranty

Delta will repair or replace, at its expense and at its option, any Delta machine, machine part, or machine accessory which in normal use has proven to be defective in workmanship or material, provided that the customer returns the product prepaid to a Delta factory service center or authorized service station with proof of purchase of the product within two years and provides Delta with reasonable opportunity to verify the alleged defect by inspection. Delta may require that electric motors be returned prepaid to a motor manufacturer's authorized station for inspection and repair or replacement. Delta will not be responsible for any asserted defect which has resulted from normal wear, misuse, abuse or repair or alteration made or specifically authorized by anyone other than an authorized Delta service facility or representative. Under no circumstances will Delta be liable for incidental or consequential damages resulting from defective products. This warranty is Delta's sole warranty and sets forth the customer's exclusive remedy, with respect to defective products; all other warranties, express or implied, whether of merchantability, fitness for purpose, or otherwise, are expressly disclaimed by Delta.